

Article

Integration of Sustainable Criteria in the Development of a Proposal for an Online Postgraduate Program in the Projects Area

Mónica Gracia Villar ^{1,2,3}, Roberto Marcelo Alvarez ^{1,3,4}, Santiago Brie ^{1,2,3}, Yini Airet Miró Vera ^{1,2,5}
and Eduardo García Villena ^{1,3,*}

¹ Higher Polytechnic School/Industrial Organisation Engineering, Universidad Europea del Atlántico, 39011 Santander, Spain

² Department of Project Management, Universidad Internacional Iberoamericana (UNINI-MX), Campeche 24560, Mexico

³ Department of Environment and Sustainability, Universidad Internacional Iberoamericana (UNIB), Arecibo, PR 00613, USA

⁴ Department of Project, Universidade Internacional do Cuanza (UNIC), Barrio Kaluanda, Cuito EN 250, Angola

⁵ Business Area, Fundación Universitaria Internacional de Colombia (UNINCOL), Bogotá 11001, Colombia

* Correspondence: eduardo.garcia@uneatlantico.es

Abstract: Regulatory dispersion and a utilitarian use of sustainability deepen the gap within the teaching–learning process and limit the introduction of sustainable criteria in organizations through projects. The objective of this research consisted in developing a sustainable and holistic educational proposal for an online postgraduate program belonging to the Universidad Europea del Atlántico (UNEATLANTICO) within the field of projects. The proposal was based on the instrumentalization of a model comprised of national and international bibliographic references, resulting in a sustainability guide with significant improvements in relation to the reference standard par excellence: ISO 26000:2010. This guide formed the basis of a sustainability management plan, which was key in the project methodology and during the development of sustainable objectives and descriptors for each of the subjects. Lastly, the entities, attributes, and cardinal relationships were established for the development of a physical model used to facilitate the management of all this information within a SQL database. The rigor when determining the educational program, as well as the subsequent analysis of results as supported by the literature review, presupposes the application of this methodology toward other multidisciplinary programs contributing to the adoption of good sustainability practices within the educational field.

Keywords: PMBOK®; sustainability; education; e-learning; projects; ISO 26000:2010

Citation: Gracia Villar, M.; Alvarez, R.M.; Brie, S.; Miró Vera, Y.A.; García Villena, E. Integration of Sustainable Criteria in the Development of a Proposal for an Online Postgraduate Program in the Projects Area. *Educ. Sci.* **2023**, *13*, 97. <https://doi.org/10.3390/educsci13010097>

Academic Editor: James Albright

Received: 21 November 2022

Revised: 9 January 2023

Accepted: 13 January 2023

Published: 16 January 2023



Copyright: © 2023 by the authors. Licensee MDPI, Basel, Switzerland. This article is an open access article distributed under the terms and conditions of the Creative Commons Attribution (CC BY) license (<https://creativecommons.org/licenses/by/4.0/>).

1. Introduction

1.1. The Sustainability Paradigm Shift

From the point of view of responsible management, different governmental and non-governmental organizations and entities have issued sets of codes of ethics and conduct, management system standards, social responsibility reports, and criteria over the last few years to integrate responsibility within investment decisions designed to achieve corporate sustainability.

In this sense, the concept of the here and now of corporate social responsibility (CSR) has been overtaken by theories of sustainability, the principles of which attempt to break away from philanthropic stereotypes [1] traditionally identified with CSR and perpetuate themselves over time [2].

However, sustainability models are generally either made up of variables with a high degree of abstraction or, erroneously, directly by indicators. These are non-holistic models, without a defined instrumentalization [3], and which, in general, do not propose a paradigm shift within the organization [4]. They also do not take into account the environmental impact of the product and/or service, while also lacking measurement criteria. This gap can be seen, for example, in the work of Hernández and Sánchez [5] and Lozano et al. [6], who propose the application of the “triple bottom line” (TBL) theory, aimed at enterprising. These studies establish a model based only on national benchmarks to analyze how sustainability influences business performance, considering only the three traditional dimensions: economic, social, and environmental.

The lack of unanimity when defining and measuring the guiding principles of CSR and sustainability makes it very difficult to integrate them with the idiosyncrasies of the organization and, consequently, gain a competitive advantage in the market.

Despite this, the International Organization of Standardization (ISO) published the ISO 26000:2010 standard “Guidelines on Social Responsibility” in 2010 [7]. The objective of this guide was to blend all the standards, guides, and models on ethics and social responsibility, focusing on the integration of certifiable standards in quality, environment, and occupational risk prevention, among others, that would enable the optimization of resources and the satisfaction of the current and future needs of all stakeholders related to the organization. The fundamental principles of the ISO 26000:2010 Guidance Standard are shown in Table 1.

Table 1. Fundamental principles of the ISO 26000:2010 Guidance Standard.

Section	Fundamental Principles
6.2	Organizational governance
6.3	Human rights
6.4	Labor practices
6.5	The environment
6.6	Fair operating practices
6.7	Consumer issues
6.8	Community involvement and development

Note: ISO (2010).

As a result of the bibliographic review, a sustainability guide was obtained based on national and international references that offered broader perspectives and more complete results in relation to ISO 26000:2010.

1.2. Sustainability in University Programs

The incorporation of sustainability criteria in university programs, and the role that universities should play as generators of knowledge, was already explicitly stated decades ago in the declarations of Stockholm 1972, Rio de Janeiro 1992, Johannesburg Summit 2002, Rio +20 2012 and, more recently, in the United Nations 2030 agenda with the incorporation of the 17 Sustainable Development Goals (SDGs, 2015).

Indeed, empowering students with the necessary skills to develop sustainable solutions by introducing the SDGs in study plans is a good way for universities to contribute toward the 2030 agenda [8].

However, despite all these initiatives and the increase in sustainability content in the classroom, current environmental, social, and ecological problems indicate that not enough progress has been made [9–11].

In effect, contributions by universities in this context have been mostly limited to environmental management as reflected in the Green Metrics ranking developed by the University of Indonesia [12]; to offering electives for specific students [13]; to incorporating one or more subjects on sustainable development within the traditional curriculum of

a program; or to quantifying the number of publications and courses on sustainable development without delving deeper into teaching–learning processes [9].

Introducing sustainable criteria in the methodology, objectives, and descriptors of all the program subjects—mandatory and elective—implies considerable structural changes in curricular processes, virtual environments, and the community actions of the institution [14]. It is because of this complexity that universities are reluctant in readapting their processes, most likely due to the lack of resources and personnel with specific training in this field [15].

A significant example is provided by the Edgewood Business School, where its administration in 2013 rethought introducing sustainability from the outset in the students' main portfolio. In spite of the benefits of a restructuring for students broadening their decision-making scope, opinions were divided among professors, most likely due to lack of training in this area [13].

Despite all this, according to [13], there are some successful experiences in this regard, such as the reorientation of the University of Plymouth (United Kingdom) towards sustainability in 2005 or the MBA postgraduate programs offered by the Saïd Business School of the University of Oxford, also in the United Kingdom.

In conclusion, training people is essential in decreasing the gap between sustainability and training and project management [16]; that is, to overcome the resistance to the paradigm shift and thus influence the strategic objectives of the organization from the project [17,18].

1.3. The Importance of e-Learning Education

Regarding the educational field, most of the models found in the bibliography are directed to face-to-face teaching and, to a lesser extent, to the distance modality, with a common practice in the former being the attribution of little relevance to new technologies which, if they appear, usually do so as one more element of the teaching itself instead of assigning it the separate relevance it deserves, as is found in the proposal by Mejías and Martínez [19].

In this sense, virtual education plays a preponderant role in satisfying the right (and the need) that everyone has to access education [20]. Between the end of the 20th century and the first decade of 2000, two approaches to virtual education emerged: a partial one, where the educational activity, educational materials, platforms and cost/benefit ratio were evaluated [21–23], and a global one, referring to evaluation systems centered on models and/or standards of total quality and on the practice of *benchmarking*. In this context, according to Pereira and Gelvez [24], as in face-to-face education programs, in the systemic models of quality evaluation in virtual education, there is no clear concept of what quality is, which determines the criteria to be assessed and, thus, why it is important to establish standards for the quality of *e-learning*.

The Spanish Association for Standardization (UNE) published in 2012 the standard UNE 66181:2012 “Quality Management. Quality of Virtual Education” [25], which determines the three factors involved in meeting the needs and expectations of students, recognizing education for employability, learning methodology, and accessibility.

The importance of having valid and reliable instruments (such as standards or guidelines) is therefore evident, due to the implications that may arise from their use [26].

Within the scope of this research, the impartation of sustainable criteria is fundamental in developing competencies in graduates and in the framework of the Sustainable Development Goals (SDGs). According to Piza-Flores et al. [27], the sustainability model should be one of the guiding principles to be included transversally (in the different curricula of the educational institution).

1.4. Sustainability and Project Management

The transversality is justified within the introduction of sustainable principles in each and every one of the knowledge areas of an online project program and for each of the process groups included by the Project Management Institute (PMI) in its “Project Management Body of Knowledge, PMBOK®” [28], which together with the standard “ISO 21500:2012, Guidance on project management” [29] are the generic standards of most relevance and acceptability referred to project management/administration/leadership.

However, it is only in recent years that sustainability criteria have been incorporated into project management, in a very discreet manner.

In this context, Figure 1 shows five key words related to sustainability models, which appear in the sixth and seventh editions of the PMBOK® and ISO 21500:2012 standards. It can be seen that there are no significant differences between the two versions of the PMBOK® and that, in general, there are very few explicit references to these terms in the three standards, especially in ISO 21500:2012.

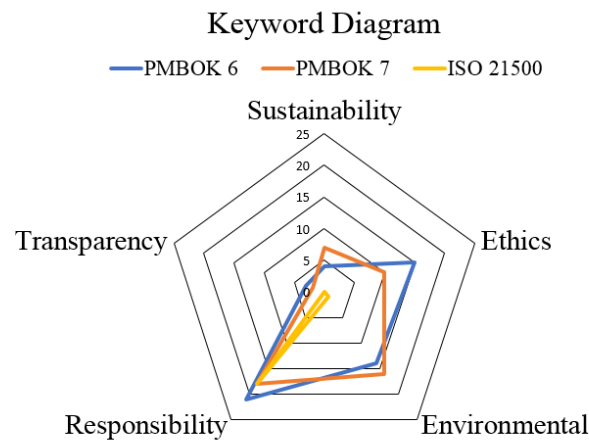

Figure 1. Posting of five keywords related to sustainability models in the PMBOK® (sixth and seventh edition) and ISO 21500:2012 project standards. Note: Own elaboration.

Although a more recent version is in force, this research work will focus on the 13 knowledge areas and five process groups (initiation, planning, execution, monitoring and control, and closure) included in the sixth edition of the Project Management Body of Knowledge Guide (PMBOK®).

For the sake of simplicity, only the processes for project integration management, i.e., those related to coordinating tasks, resources, and stakeholders, among others, have been named in Table 2. Additionally, the authors added a new knowledge area to the table relating project sustainability management (shaded), of which the sustainability management plan is a part and which will be discussed below.

Table 2. Map of Proposed Processes to Integrate the Sustainability Model in the Online Training Program on a Project.

Knowledge Area	Process Groups				
	Initiating	Planning	Executing	Monitoring and Controlling	Closing
4. Project Integration Management	4.1. Develop Project Charter	4.2. Develop Project Management Plan	4.3. Direct and Manage Project Work 4.4. Manage Project Knowledge	4.5. Monitor and Control Project Work 4.6. Perform Integrated Change Control	4.7. Close Project or Phase
...
14. Project Sustainability Management		14.1. Plan Sustainability Management	14.2. Manage Sustainability	14.3. Control Sustainability	

Note: Only the most significant processes and knowledge areas of the case study are shown in the table. It can be noted that the processes always start with a verb, unlike the knowledge areas. Note that the authors of this research have added a new knowledge area related to “project sustainability management.” Adapted [28].

These processes are differentiated throughout the project life cycle, which is immersed in one or more other life cycles corresponding to the products generated by the project or to the business cycles of the organizations (Figure 2). In this regard, each of the project life cycle stages is associated with the process groups of initiation, planning, execution, monitoring and control, and closure, from the PMBOK Guide® [28].

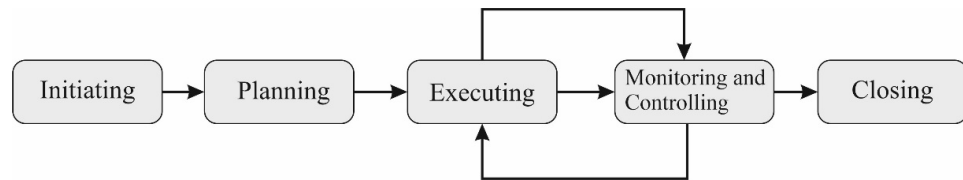

Figure 2. Project life cycle.

Each of these processes produces one or more outputs from one or more inputs through the use of appropriate project management tools and techniques. The output may be a deliverable or a result that is the end result of the process.

Figure 3 illustrates the components of a process.

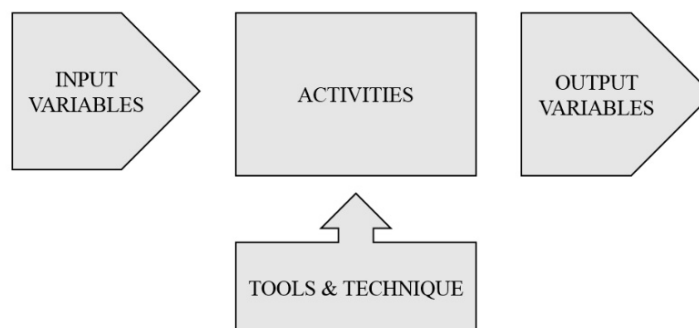

Figure 3. Components of a process. Adapted from [28].

According to Bravo et al. [30], the use of these processes increases the chances of success of a wide variety of project management standards and the implementation of programs complementary to the PMBOK Guide, which contribute toward the coordination

of resources and improve managing an organization's elements, such as "The Standard for Program Management" [31] and "The Standard for Portfolio Management" [32].

Lastly, it was essential to incorporate a work methodology that integrated the teaching of abstract concepts through a sustainability model, with the praxis of a project and the virtual dimension of a collaborative environment, such that new knowledge was generated that represented a framework of opportunities, not only for the university to transform itself favorably in the educational sector, but also to expand specific services on its present and future projects, in this case, the academic programs [33].

1.5. Research Design

As mentioned in the abstract, the objective of this research work was to introduce sustainable criteria in a postgraduate educational program in online projects at the Universidad Europea del Atlántico from a holistic perspective, i.e., involving both the development phase of the subjects in time, scope, and cost, as well as the teaching-learning process.

The difficulties encountered by the institutions in carrying out this purpose, often related to lack of resources and staff experience, have been discussed in the theoretical framework.

Thus, once the objective and the problem were established, the research question was as follows:

Is it possible to develop a holistic model capable of developing the individual capabilities of project managers by incorporating sustainable criteria in its methodology and in the results of the teaching-learning process of the online Master's in Projects educational program?

In reference to the research sub-questions:

- Is it possible to bridge the gap between sustainability and project methodology? What about sustainability and training at the project level?
- How can utilitarianism be avoided when applying sustainability criteria to an online graduate program within the project environment?
- Is it possible to represent the sustainable traceability of the subject through a sustainability management plan?
- How can new technologies facilitate the current paradigm shift that sustainability represents?

2. Materials and Methods

The methodology followed in this research was exploratory and descriptive based on triangulation; that is, information from different sources was contrasted [34]. It also had a qualitative, non-experimental, cross-sectional approach, since no hypotheses were proposed and no variables were manipulated, but "[...] data was measured, evaluated or collected on various aspects, dimensions or components of the phenomenon to be researched [in its natural working environment and at a single time]" [35,36].

A relevant aspect of the research was the development of a sustainability management plan for each of the subjects, supported by a sustainability guideline, improved in relation to the ISO 26000:2010 reference standard.

The sustainability guideline was prepared based on management models, guides, and tools and, more importantly, on conceptual definitions of the variables or areas of knowledge of sustainability stemming from the review of the bibliography by means of expert judgment and other documented information.

Table 3 shows the variables or areas of knowledge used in this research and their associated bibliographic sources.

Table 3. Sustainability Model Variables and References Consulted.

Model Variables for Sustainability	References
Responsible logistics and operations	[37]
Sustainable resource management	[38]
Environment	[37–42]
Socially responsible people management and quality	[37–41,43,44]
Socially Responsible Investment	[7,37,38]
Sustainability culture and values	[7,40,41]
Quality of products and/or services	[45,46]
Corporate governance	[37,40,46]
Community	[44,46]
Socially responsible policy and strategy	[7,37,40,46]
Sustainable leadership	[46]
Governance	[46]
Shareholders	[46]
Suppliers and partners	[42,44,46,47]
Clients, users and consumers	[46,47]
Communication (transversal)	[47]
Information media	[47]

Note: Updated from [48].

In its methodological stage, the sustainability management plan facilitated the implementation of sustainability criteria in the process groups (initiation, planning, execution, monitoring, and closure) included in the Project Management Institute’s (PMI) “Project Management Body of Knowledge, PMBOK®” Guide [28]. In this sense, it helped to minimize the utilitarian conception that prevails in most project standards and norms, which represents a problem for sustainability durability once the project has been implemented [49].

Lastly, Microsoft SQL Server Manager Studio v.18.12.1 was used for the implementation in SQL code of a physical database model for sustainability, consisting of five entities (professors, students, courses, subjects, and a virtual classroom), with their corresponding attributes and cardinal relationships, which was essential in speeding up the implementation of the teaching–learning process of the master’s degree in projects at the institution.

2.1. Materials and Subjects

The subjects of the master’s degree in projects from the Universidad Europea del Atlántico were grouped into different materials, as shown in Table 4.

Table 4. Materials and subjects of the master’s program in projects from the Universidad Europea del Atlántico.

Materials	Target	Subjects
Project Design	Define the objectives, the required human and material resources, and the indicators for monitoring and verifying the expected results, among other things, based on the outlined strategy.	Introduction to projects
		Design of project systems
		Analysis of the services to be provided
		Functional analysis in the project
		Specifications in the project
Project Management	Carry out the planning, recruitment, and organization of the team and administration of other resources, among other things defined in the previous phase, to meet the objectives in time and cost.	Preparation of the preliminary project
		Project monitoring and control
		Strategic human resources management
		Project communication
		Quality of the product and/or service
		Cost management
		Trust and risk management
Procurement management		
		Project stakeholder management

Materials	Target	Subjects
Project Evaluation	Answer the question of whether it will meet the identified needs, what environmental and social impacts it will have on the environment, what benefits will be obtained or when the investment will be recovered. All this will establish the decision to accept or reject it, either temporarily or definitively.	Project market Project profitability Social investment projects Technology and environment in the project Project risk and uncertainty
Strategic Project Management	Apply knowledge, skills, and techniques to execute projects efficiently and effectively.	Project governance Conflict resolution and mediation Team management techniques Management and strategic planning Virtual collaborative work environments

2.2. Sustainability Management Plan

Figure 4 illustrates the methodology used to develop the subjects of the online master’s degree in projects and how they fit within the processes included in the Project Management Body of Knowledge Guide (PMBOK®). Participation of the sustainability management plan as another document within the project development management plan has been highlighted in red.

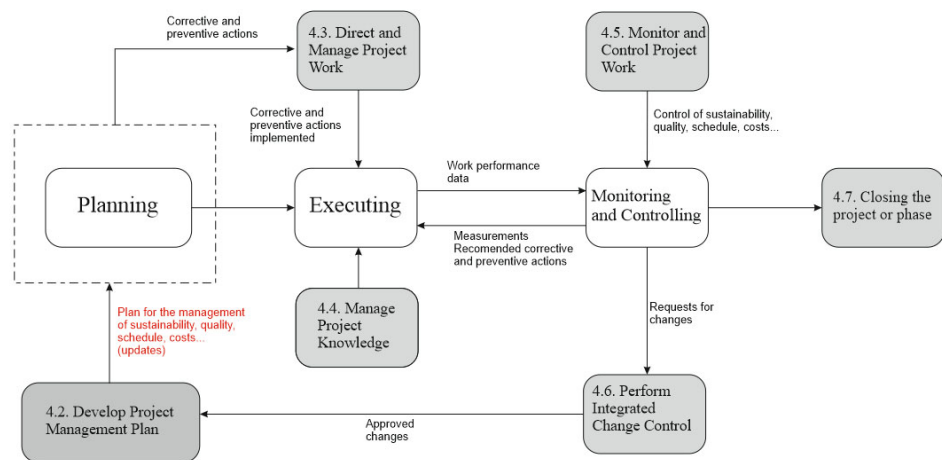

Figure 4. Planning, execution, and monitoring and control stages of the development of subjects of the online master’s degree in projects. Note: The color red highlights the inclusion within the planning stage of the sustainability management plan. Own elaboration.

2.3. Relational Schema and Physical Database Model for Sustainability

As illustrated in Figure 5, an entity relationship diagram (ERD) was created to illustrate the university’s business model in relation to the relationship between the different entities described by means of connecting lines, visualizing attributes and quantifying the relationship between instances (cardinality).

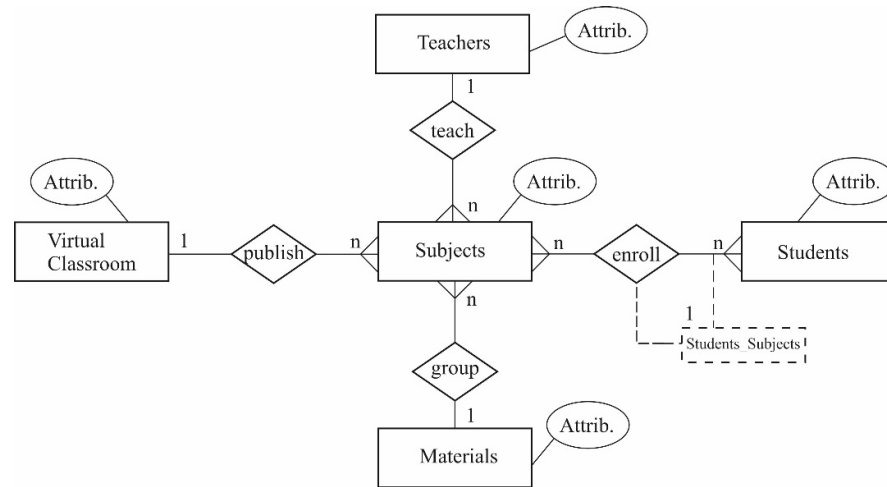

Figure 5. Relational structure with the identities, attributes, and cardinal relationships included in the database.

In relation to cardinality, it was considered that:

- Professors may teach one or more subjects, but a subject can only be taught by one professor (cardinality 1:n).
- The program groups one or more subjects; however, a subject can only belong to one program (cardinality 1:n).
- The virtual campus has one or more subjects but these can only belong to one virtual campus (cardinality 1:n).
- One or several students can take one or several subjects of the program (modularity), just as the same subject can be taken by one or several students (cardinality n:n).

This relational structure was converted to a physical model, which served as the basis for developing the code to be implemented in SQL. In this regard, Figure 6 illustrates the physical model with its corresponding relationships, tables, and attributes.

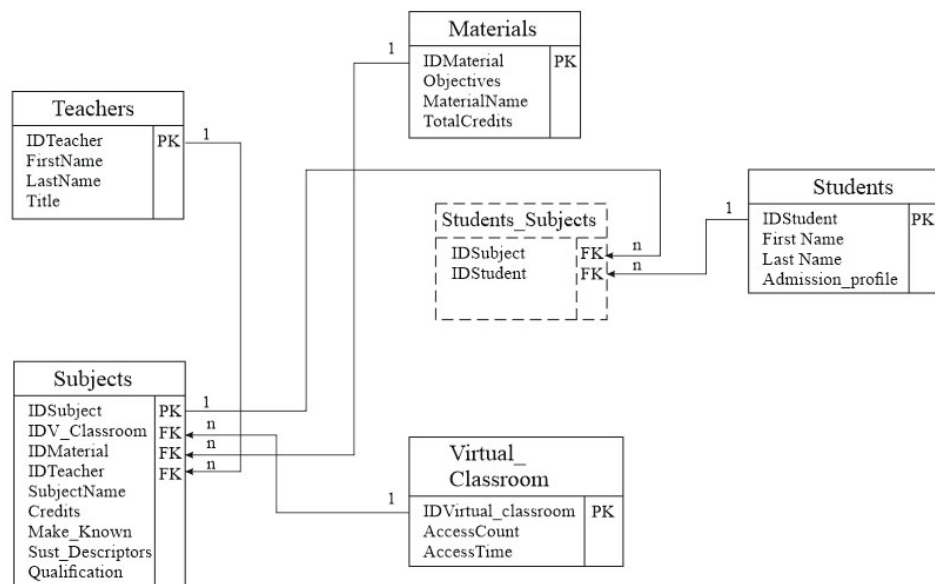

Figure 6. Tables and attributes of the physical database model. Note: The cardinal ratio n:n has been transformed to 1:n by introducing a transitive intermediate table (dotted line).

2.4. Panel of Experts

The panel of experts for the first three sections consisted of a total of two professors from the university, who teach in the environmental engineering and occupational risk prevention postgraduate programs.

The structure of the sustainability management plan, the allocation of resources and the definition of decision criteria were carried out by three professors from the environmental management graduate program in the projects area.

Lastly, an IT doctoral profile was in charge of creating the sustainability database and the physics model and implementing a code in SQL.

3. Results

3.1. Obtaining Variables, Factors, and Indicators for Sustainability

Table 5 shows an example of the factors associated with the variable “Logistics and responsible operations”. It can be seen how the degree of abstraction is decreasing. Logically, an indeterminate number of factors can be identified, depending on the conceptualization of the phenomenon under study.

Table 5. Determination of the “Logistics and Responsible Operations” Variable Factors Based on its Conceptual Definition.

Variable	Responsible Logistics and Operations
Theoretical definition	Defined as the set of means and methods necessary to carry out the organization of a company or a service, especially that of distribution.
Conceptual definition	Study, research, management, and development of activities related to the availability of resources to handle the processing of finished products, customer orders, dispatch orders, packing and packaging, handling transporters, deliveries, follow-up, and arrival of conformities [50].
Factor	Availability of human and material resources.

Table 6 shows an example of the indicators associated with the “Gender Equity and Equality” factor.

Table 6. Determination of the Indicators of the “Gender Equity and Equality” Factor Based on its Operational Definition.

Variable	Socially Responsible People Management and Quality
Factor	Gender Equity and Equality
Conceptual definition	Gender equity is understood as impartial treatment between women and men according to their respective needs, either with equal treatment or with differentiated but considered equivalent treatment in terms of rights, benefits, obligations, and possibilities. Gender equality is understood as a situation in which women and men have the same possibilities, or opportunities in life, to access and control socially valuable resources and assets [51].
Operational definition	Equal distribution of government tasks between men and women and equity in terms of salaries through the implementation of equal opportunity programs.
Indicator	Degree of women’s participation in government tasks. Demographic, social, and economic characteristics of the worker.

3.2. Creation of a Sustainability Guideline

The sustainability guideline was developed following a systemic process approach in all its phases of development, implementation, and effectiveness improvement in its application toward the educational institution, with the aim of increasing stakeholder satisfaction through the fulfillment of its objectives.

This guideline offers numerous definitions and concepts that appear in the ISO 26000:2010 standard and other norms and standards of interest, complemented with documented information found as a result of the research, representing added value to expand the detail of some concepts and provide a series of recommendations and aids to facilitate the integration of sustainability in the objectives, descriptors, and methods of the online master’s degree in projects.

Table A1 in Appendix A illustrates the structure of the chapters and sections of the guideline.

3.3. *What’s New in the Sustainability Guideline vs. ISO 26000:2010*

As can be seen, the references that are not explicitly included in the CSR standard refer to environmental risk, the life cycle of the product and/or service provision, and job analysis, description, and specifications (Table 7).

Table 7. Innovations in the Sustainability Guideline vs. the ISO 26000:2010 Core Subjects.

ISO 26000:2010 Core Subject	Innovation Sustainability Guideline	Measures to Be Included in ISO 26000:2010
6.5. Environment	5.2. Environmental risk management	The chemical accident prevention and preparedness program should include, among other things, emergency drills, training, hazard identification and risk assessment, notification procedures and communication systems, and accident rates, as well as public information education.
	5.5. Life cycle analysis of products and/or services.	Inclusion of reference to standards such as ISO 14040 [52] to, among other things, measure the environmental impact of the product and/or service. References to the generation of eco-labeled products
6.4. Labor Practices	6.13. Job analysis, description, and specifications	References to the calculation of the carbon footprint of products and/or services using the PAS 2050 standard [53].
		Updated records describing the particularities of every job position, degree of detail, and associated risks (professional profile). Implementation of improvement actions resulting from the evaluation of the results achieved.

3.4. *Structure of a Sustainability Management Plan*

To avoid a utilitarian conception of sustainability, a management plan was drawn up for each of the subjects, reflecting the sustainability criteria corresponding to the methods, objectives, and descriptors.

Thus, the general structure of the sustainability management plan is shown in Table 8.

Table 8. Structure of the Sustainability Management Plan.

1. Program Mission
To provide quality education to meet the educational needs of the people.
2. Program Vision
To become a benchmark institution for its teaching methodology based on sustainability.
3. Values
Sustainability, commitment, good teaching practices.

4. Program Objective	
To train professionals in project practices and disciplines that contribute sustainable value to organizational processes.	
5. Scope of the Subject Project	
Comprehensive management of the subject project (incorporation, identification of stakeholders, development of the management plan, execution and control, closure, and termination).	
Logistical area (author(s) recruitment, student management, procurement management...)	
Technical–legal area (identification of applicable legislation, identification of risks...)	
Organizational (organization of human resources, stakeholder awareness, etc.)	
Performance scope (development of the subject, delivery of the subject, subject evaluation systems, etc.).	
6. Institutional Sustainability Policy	
The subject project must be aligned with the sustainability indicators required by the educational institution and in accordance with the base requirements of scope, costs, and schedule.	
7. Sustainability Objectives of the Subject	
Identify and assess possible negative impacts of the subject project.	
Establish preventive and corrective measures to eliminate or minimize the negative impacts of the subject project.	
8. Stages	
8.1. Initiation	Necessary procedures
	Drawing up the minutes of incorporation of the subject project.
8.2. Sustainability management planning	Identify stakeholders
	Develop the project management plan of the subject.
	Determine subject descriptors
	Determine the sustainability factors of the subject matter
	Estimate baselines (time, costs...)
8.3. Execution	Develop the budget for the subject project.
	Estimate procurement needs
	Incorporate sustainability objectives, descriptors, and factors into the sustainability database.
	Develop the contents of the subject
	Teach the subject
8.4. Monitoring and controlling	Evaluate education and delivery
	Manage communications
	Control changes
8.5. Closing	Conduct student satisfaction surveys
	Write sustainability reports
	Close the subject project
9. Roles and Responsibilities	
Assignment of the project manager and the project team	
Levels of authority	
10. Sustainability Tools and Techniques	
Regulations, cost–benefit analysis, simulations, mapping process, flowcharts, etc.	
11. Sustainability Metrics	
Set of performance indicators for sustainability	

3.5. Database Application

Table 9 shows an example of the implementation of the code in SQL, based on the physical model in Figure 6, applied to the combination of some attributes of the tables “Materials” and “Subjects”.

Table 9. Database structure applied to the tables of Materials and Subjects.

ID	ID Material	Material Name	Subject Name	Make_Known...	Sust_Descriptors
1	1	Project Design	Design of project systems	The formulation of sustainability learning objectives...	Identification of the sustainable project scenario...
2	2	Project Management	Strategic human resources management	The guiding principles of an ISO 45001...	Reconciliation of personal, family, and work life...
3	2	Project Management	Project communication	Two-way communication channels for employee participation...	Internal communication and employee participation...
4	1	Project Design	Preparation of the preliminary project	Sustainability specifications developed and established...	Elaboration of a sustainable pre-project proposal...
5	3	Project Evaluation	Project market	Studies and capabilities for forecasting the growth...	General aspects of the sector. Background study...
6	4	Strategic Project Management	Project governance	Internal codes of conduct, ethics...	Sustainability culture and values...
7	4	Strategic Project Management	Conflict resolution and mediation	Procedures to settle and mediate in the peaceful and non-violent...	Judicial and extrajudicial mediation mechanisms...
8	2	Project Management	Cost management	Ethical, social, and environmental principles in the investment...	Direct economic value generated and distributed...

Full Examples of descriptors and objectives for sustainability are shown in Tables A2–A6 in Appendix A.

4. Discussion

In this research article, a sustainability model composed of a set of variables was developed, to be subsequently instrumentalized in an online postgraduate training program in the field of project management. Despite the terminological confusion and heterogeneity existing among sustainability tools, it confirms the commitment of the university, as a human organization, to incorporate a sustainability code that allows it to maintain its idiosyncrasy and establish identity links with the environment. Indeed, authors such as [54] consider that the environment, and in particular the stakeholders, should play a fundamental role in decision-making. Along the same lines, [55] mentions the importance of maintaining a good reputation under a global and integrating approach in which the organization’s responsibility is assumed before society in general. This confirms, therefore, the importance of sustainability models to create and contribute value in the university in relation to the “triple bottom line” and environmental management of the product and/or service, through socially responsible investment, labor practices and human rights, use of environmental protection instruments, life cycle analysis, etc.

The operationalization of the model’s variables was the first step in obtaining the sustainability factors and indicators. This step was necessary because, being made up of variables, the degree of abstraction of a model is very high and has no practical application per se unless it is instrumentalized in a management tool. In this context, the operationalization of variables has been studied by several authors such as [56], [57] and [58], but always from the point of view of the “triple bottom line”. Other authors, such as [26], justify the importance of having, at least, valid and reliable instruments (such as standards or guidelines). In the same line, [55] refers to the fact that combining all these interests (ethical, environmental, social, economic...) forces organizations to look for tools (based

on continuous improvement) that enable the observation, measurement, and manipulation of these variables. Thus, it concludes that the operationalization of variables is necessary in the creation of a new instrument and obtaining the sustainability factors, which will be part of the methods, objectives, and descriptors of the different subjects of the online training program.

By implementing the model in a sustainability guideline, it was possible to create synergies and complementarities with the ISO 26000:2010 Social Responsibility Guideline. This was very useful, because, as a result of the comparison, it was possible to detect gaps and shortcomings between the two instruments. Thus, it was interesting to add a number of new features to the sustainability guideline, including a fourth dimension that takes into account the environmental impact of the product and/or service provision throughout its life cycle. In this regard, it has been found that most sustainability management tools are eminently theoretical, so they do not provide measurement indicators and, when they do, they refer to the Global Reporting Initiative [40]. Likewise, there are still shortcomings in most standards, especially with regard to the impossibility of ISO 26000:2010 certification, the absence of a basis of measurement indicators, and the explicit assessment of the impact of the product or service [48].

Far from a utilitarian conception of the term, in this research, the sustainability guideline was used to introduce sustainable criteria in the processes included in the sixth edition of the PMBOK® project management standard [28]. This means that the creation of sustainable value occurs not only in the final product, i.e., in the objectives and descriptors of the subjects, but also in the development methodology of the training program, thus giving the master's in projects a holistic character. In line with the interpretation made by ISO 9001:2015 [45], the PMBOK® guide [28] was considered as a complement for the implementation of the sustainability guideline, i.e., as a reference framework, which could be implemented using other methodologies and tools compatible with the knowledge areas and the process approach. This is corroborated by [59], who consider that the best way to integrate sustainability or other criteria into a standard is to develop another tool from a model and establish equivalences between them. In the same sense, [60] equates the project management standard with a customizable guide, adapted to any type of scope, industry, or project culture, unlike other authors such as [61], who consider it as a project methodology. In conclusion, it is necessary to create new holistic frameworks that break away from traditional standards and consider metrics at every point in the project life cycle.

In order to summarize all of the above, the sustainability management plan was structured for each of the subjects in the training program. This document is essential for the sustainable planning of the subject, since it contemplates the guidelines for incorporating sustainability criteria throughout its life cycle. In fact, authors such as [62] consider that the planning phase is the one with the greatest potential for sustainability at the lowest cost. Along the same lines, [63] consider such a plan as a planning tool that plays a fundamental role in decision-making and change control in the project. In short, it is a tool that helps to interpret the scope and clarify the work of the subject, containing its attributes and methods as well as procedures for the determination of metrics and control.

Finally, technological tools can help to reduce the gap between sustainability and project management, facilitating integration and creating synergies between the different instruments. In this research, a small code connected to a database was developed, which allows identifying the sustainable criteria that affect each of the subjects. However, as it has been seen, they can be used to develop skills among students by ensuring, in addition to the delivery of knowledge, how to process it through satisfaction assessment tools and application in practice. In the same line, [64] determines the three main factors involved in satisfying students' needs and expectations: recognition of training for employability, learning methodology, and accessibility.

5. Conclusions

The training itinerary presented in this research responds to a holistic model, enabling the development of individual project managers' skills in sustainability and, consequently, reducing the existing gap between this paradigm, project methodology, and training in this field.

The approach to sustainability taken in this article goes beyond the addition of a label or a subject on good sustainable practices to the traditional student portfolio. The aim is to include ethical, social, environmental, and product responsibilities, both in the methods and in all the subjects of an online educational program, to minimize a project's impacts on the environment.

Regarding the second research sub-question, a sustainability guide was obtained that includes concepts that do not appear in ISO 26000:2010, such as job analysis and specifications, environmental risk, and the life cycle of the product and/or service provision. Unlike traditional standards, the instrument is applied at all stages of the subject life cycle, thus avoiding a utilitarian use, which would limit the durability of sustainability over time.

In this sense, relating to the third and fourth research sub-questions, the sustainability management plan and technology play a very important role in the planning and sustainable traceability of the subjects throughout their life cycle, as they introduce sustainability into the project methodology and facilitate the consultation, modification, and implementation of sustainability criteria, respectively.

In the end, this research will hopefully help, among other issues, to reduce the gap between project management and sustainability, for which it is very important to acquire a holistic vision and develop critical capabilities for the creation of sustainable value in the foundations of project manager thinking.

Author Contributions: Conceptualization, M.G.V. and R.M.A.; data curation, M.G.V. and E.G.V.; formal analysis, M.G.V.; investigation, R.M.A. and S.B.; methodology, E.G.V. and Y.A.M.V.; project administration, M.G.V. and S.B.; resources, M.G.V. and R.M.A.; software, S.B.; supervision, E.G.V.; validation, S.B. and M.G.V.; visualization, Y.A.M.V.; writing—original draft, E.G.V. and M.G.V.; writing—review and editing, E.G.V. and Y.A.M.V. All authors have read and agreed to the published version of the manuscript.

Funding: This research is part of European Project Erasmus + Lovedistance (Reference: 609949-EPP-1-2019-1-PTEPPKA2-CBHE-JP), funded by the EACEA (Education, Audiovisual and Culture Executive Agency), European Commission.

Institutional Review Board Statement: Not applicable.

Informed Consent Statement: Informed consent was obtained from all subjects involved in the study.

Data Availability Statement: The data presented in this study are available on request from the corresponding author. The data are not publicly available due to the conditions of the project contract with the funder (Society for Regional Development of Cantabria).

Acknowledgments: The authors would like to thank the Cantabria Center for Industrial Research and Technology (CITICAN, Centro de Investigación y Tecnología Industrial de Cantabria) and the Universidad Europea del Atlántico for their valuable collaboration.

Conflicts of Interest: The authors declare no conflicts of interest.

Appendix A

Table A1. Description of the Sustainability Guideline Chapters.

Chapter	Factors/Section
1. Introduction	The nature, principles, approach, and compatibility with other management tools are described
2. Purpose and field of application	The purpose of the guideline and its scope of action are defined
3. Reference documents	Standards, guidelines, and other reference documents for implementation
4. Terms and definitions	Meaning of key sustainability terms in general, and for the use of this guideline in particular
5. Environment	5.1. Pollution prevention and control
	5.2. Environmental risk management
	5.3. Biodiversity preservation
	5.4. Fight against climate change
	5.5. Life cycle analysis of products and/or services
6. Socially responsible people management and quality	6.1. Occupational health and safety conditions
	6.2. Reconciliation of personal, family, and work life
	6.3. Gender equity and equality
	6.4. Conflict resolution
	6.5. Diversity and non-discrimination
	6.6. Human Rights
	Civil and political rights
	Economic, social, and cultural rights
	6.7. Forced and child labor and respect for the dignity of workers
	6.8. Other working conditions and social protection
	6.9. Selection, hiring, and stability
	6.10. Education, training, and competence
	6.11. Physical accessibility of workplaces and work environments
6.12. Internal communication and employee participation	
6.13. Job analysis, description, and specifications	
7. Community	7.1. Promotion of local development
	7.2. Preservation of traditions and rights of indigenous communities
8. Suppliers and partners	8.1. Identification, evaluation, and selection of suppliers and partners
	8.2. Follow-up of suppliers and partners
9. Market	9.1. General aspects of the sector
	9.2. Potential customers
	9.3. Entry barriers
10. Customers, users, and consumers	10.1. Confidentiality and privacy of data
	10.2. Customer, user, and consumer profile
	10.3. Accessibility to essential services
11. Resources	11.1 Sustainable material consumption and energy efficiency
	11.2. Water conservation and access
12. Sustainability policy and strategy	12.1. Mission, vision, and objectives
	12.2. Sustainability culture and values
13. Communication and media	13.1. Communications with customers, users, and consumers
	13.2. Sustainability reports
	13.3. Communication with suppliers and allies
	13.4. Information society and managerial means of product and/or service dissemination
14. Governance	14.1. Good corporate governance practices
15. Sustainable leadership	15.1. Leadership and management style
16. Quality of project deliverables	16.1. Sustainability, safety, health, and accessibility of products and services
	16.2. Fair marketing practices
17. Responsible research, development, and innovation (R&D&I)	17.1. Innovation and development

18. Economic-financial area (Income tax)	18.1. Direct economic value generated and distributed
	18.2. Direct economic value generated and not distributed
	18.3. Economic value received, Income tax
19. Public authorities	19.1. Aspects related to honesty
	19.2. Interference in the field of public policies
20. Competition	20.1. Respecting competitors' property rights
	20.2. Right to free competition
21. NGO's	21.1. Economic, political, social, and technological relations
22. Responsible logistics and operations	22.1. Logistics Availability of human and material resources
	22.2. Reverse logistics Material and energy recovery of the finished product
Annex I: Table of equivalences and new developments: sustainability guideline vs. ISO 26000:2010 guideline	The chapter equivalences of this sustainability guideline and those of the ISO 26000:2010 standard are detailed, as well as the most important new features introduced by the former with respect to the latter.
References	References to texts and other sustainability management tools mentioned throughout the Guideline are provided.

Table A2. Subjects and Descriptors on Sustainability of the “Project Design” Area.

Area: Project Design	
Subject	Sustainability Descriptors
Introduction to projects	Sustainable project design and methodology. Characteristics of the systems to be designed and projected
Design of project systems	Identification of the sustainable project scenario. Technical problem statement. Formulation of sustainability objectives. Sustainable criteria to evaluate the success of the project. Sustainability in the man-artificial system-environment trilogy
Analysis of the services to be provided	Social responsibility and sustainability in the supply chain. Sustainable engineering solutions. Desired service vs. delivery conditions
Functional analysis in the project	Sustainability information analysis with stakeholders. Sustainable project development planning. Sustainable management tools to determine the functions and services to be provided by the project
Specifications in the project	Documented sustainable information. Sustainability standards and norms. Reliability and details of supply. Sustainability conditions for project reliability
Preparation of the preliminary project	Elaboration of a sustainable pre-project proposal. Sustainability strategies to be considered. Preliminary project specification tools

Table A3. Subjects and Descriptors on Sustainability of the “Project Management and Monitoring” Area.

Area: Project Management and Monitoring	
Subject	Sustainability Descriptors
Strategic human resources management	Reconciliation of personal, family, and work life. Gender equity and equality. Diversity and non-discrimination. Civil and political rights. Forced and child labor and respect for the worker's dignity. Selection, hiring, and stability. Job analysis, description, and specifications. Education, training, and competency. Physical accessibility to jobs and work environments. Other working conditions and social protection
Project communication	Internal communication and employee participation. Communication with suppliers and partners. Communications with customers, users, and consumers. Confidentiality and data privacy. Oral presentations. Facilitation workshops. Monitoring and control. Sustainability reporting
Quality of the product and/or service	Sustainability, safety, health, and accessibility of products and services. Information on products and services. Fair marketing practices. Quality control. Audit plan. Material and energy recovery of the finished product. Product certifications

Cost management	Direct economic value generated and distributed. Direct economic value generated and not distributed. Economic value received (socially responsible investment). Donations
Trust and risk management	Adequate response plan to risk exposure. Minimization of threats. Exploitation of opportunities. Risk monitoring
Procurement management	Criteria for sustainable selection of physical and human resources in terms of availability, cost, and capacity. Code of ethics. Virtual team building through ICTs. Control of resources and acquisitions.
Project stakeholder management	Identification, evaluation, and selection of suppliers and partners. Follow-up of suppliers and partners. Second party audits. Client, user, and consumer profile. Accessibility to essential services. Information society and managerial means of product and/or service dissemination. Economic, political, social, and technological relations (NGOs).

Table A4. Subjects and Descriptors on Sustainability of the Area “Project Evaluation”.

Area: Project Evaluation	
Subject	Sustainability Descriptors
Project market	General aspects of the sector. Background study. Demand of potential clients. Entry barriers
Project profitability	Social profitability vs. economic profitability. Compensation of the monetary deficit. Subsidies, grants, and aids
Social investment projects	Promotion of local development. Preservation of traditions and rights of indigenous communities. Private vs. social evaluation
Technology and environment in the project	Pollution prevention and control. Environmental risk management. Biodiversity preservation. Fight against climate change. Life cycle analysis. Environmental impact assessment. Compliance with legal or social regulatory requirements
Project risk and uncertainty	Socioeconomic risk mitigation measures. Sensitivity analysis of Sustainable projects

Table A5. Subjects and Descriptors on Sustainability of the Area “Project Management”.

Area: Project Management	
Subject	Sustainability Descriptors
Project governance	Sustainable culture and values. Aspects related to honesty. Interference in the field of public policy. Mission, vision, and objectives. Good corporate governance practices.
Conflict resolution and mediation	Judicial and extrajudicial mediation mechanisms. Implementation protocols for conflict resolution and mediation.
Team management techniques	Rules for teamwork. Methodology for meetings and work sessions. Instruments for the consolidation of work teams. Collective decision making in the field of sustainability.
Management and strategic planning	Leadership and sustainable management style. Establishment and communication of institutional values. Projection of sustainability inside and outside the organization. Political and economic rights. Respect for competitors’ property rights. Right to free competition.
Virtual collaborative work environments	Interaction between people. Collaboration, cooperation, and shared work. Socio-cultural approaches to learning. Critical thinking for problem solving among people. Group dynamics. Technologies for shared work.

Table A6. Sustainable Teaching Objectives of the Subject “Strategic Human Resources Management”.

Area: Project Management and Monitoring
Subject: Human Resources Strategic Management
Make known ...
The guiding principles of an ISO 45001 occupational health and safety management system
Current occupational health and safety legislation
The rights to association, collective bargaining, union action, privacy...
Protocols for hazard identification and risk assessment in the workplace
Standards for work–life balance management, e.g., EFR 1000 1.2
Job analysis, job descriptions, and job specifications
Programs and mechanisms for gender equity and equal opportunities between men and women
Explicit policies of non-discrimination on the basis of race, sex, maternity, paternity, beliefs, ideology, sexual orientation, nationality, social origin, age, disabilities, or other distinguishing characteristics
Preventive and corrective measures for behaviors that violate the dignity of workers, especially those that fall under the concepts of moral or sexual harassment and/or violence in the workplace
Special programs for the hiring of people with disabilities, according to current legislation
The guidelines of the ILO conventions in relation to the minimum working age (ILO, art. 2, 1)
Training plans, through the diagnosis of the organization’s needs in this area, monitoring and evaluation of competencies
Current legislation on health and accident insurance, unemployment protection, among others, prioritizing stable, permanent local labor contracts over other types of contracts, and avoiding irregular hiring practices
Information on the code of ethics and other aspects related to the sustainable management system that have an impact in its areas of responsibility
...

References

- Andreu, A.; Fernández, J.L. De la RSC a la sostenibilidad corporativa: Una evolución necesaria para la creación de valor. *Harv. Deusto Bus. Rev.* **2011**, *207*, 5–21. Available online: <https://www.harvard-deusto.com/de-la-rsc-a-la-sostenibilidad-corporativa-una-evolucion-necesaria-para-la-creacion-de-valor> (accessed on 11 November 2022).
- Uribe, M.E.; Vargas, O.A.; Merchán, L. La responsabilidad social empresarial y la sostenibilidad, criterios habilitantes en la gerencia de proyectos. *Entramado* **2017**, *14*, 52–63. <https://doi.org/10.18041/entramado.2018v14n1.27107>.
- Bestatén, M.; Carboneras, M.A. *Integración de sistemas de gestión: prevención de riesgos laborales, calidad y medio ambiente*. Nota Técnica Prevención nº 576, **2006**.
- Sánchez, N. La Sostenibilidad en el Sector Empresarial. Importancia de los Distintos Grupos de Interés en el Proceso de Cambio. Master’s Thesis, UPC Universitat Politècnica de Catalunya, Barcelona, Spain, 2012.
- Hernández, F.; Sánchez, J.P. Análisis del efecto de la responsabilidad social empresarial en los resultados empresariales de las micro, pequeñas y medianas empresas (Mipymes). *GCG Rev. Glob. Compet. Gob.* **2016**, *10*, 110–123. <https://doi.org/10.3232/GCG.2016.V10.N1.06>
- Lozano, R.; Carpenter, A.; Huisingh, D. A review of ‘theories of the firm’ and their contributions to Corporate Sustainability. *J. Clean. Prod.* **2015**, *106*, 430–442. <https://doi.org/10.1016/j.jclepro.2014.05.007>
- International Organization of Standardization. *Guidance on Social Responsibility ISO 26000*; International Organization of Standardization: Geneva, Switzerland, 2010.
- SDSN Australia/Pacific. *Getting Started with the SDGs in Universities: A Guide for Universities, Higher Education and Institutions, and the Academic Sector*; Sustainable Development Solutions Network—Australia/Pacific, New Zealand and Pacific Edition: Melbourne, Australia, 2017. Available online: <https://resources.unsdsn.org/getting-started-with-the-sdgs-in-universities> (accessed on 9 January 2023).
- Geli, A.M.; Collazo, L.; Mulà, I. Contexto y evolución de la sostenibilidad en el curriculum de la universidad española. *Rev. Educ. Ambient. Sostenibilidad* **2019**, *1*, 1102. https://doi.org/10.25267/Rev_educ_ambient_sostenibilidad.2019.v1.i1.1102
- Azcárate, P.; Navarrete, A.; García-González, A. Aproximación al nivel de inclusión de la sostenibilidad en los currícula universitarios. *Profr. Rev. Curric. Form. Profr.* **2012**, *16*(2), 105–119.
- Benayas, J.; Marcén, C.; Alba, D.; Gutiérrez, J.M. *Educación Para la Sostenibilidad en España. Reflexiones y Propuestas*; Fundación Alternativas y Red Española para el Desarrollo Sostenible: Madrid, Spain, 2017. Available online: https://www.fundacionalternativas.org/storage/opex_documentos_archivos/81ef826c30f2322a5c9c8536a50faf20.pdf (accessed on 9 January 2023).
- UI Green Metric. World University Rankings. Overall Rankings 2022. Available online: <https://greenmetric.ui.ac.id/rankings/overall-rankings-2022/> (accessed on 9 January 2023).

13. Martín-Mendiluce, I. *La Enseñanza en Sostenibilidad en los Planes de Estudio de las Escuelas de Negocio del Mundo [Trabajo de Fin de Grado]*; Universidad Pontificia de Comillas: Madrid, Spain, 2019. Available online: <https://repositorio.comillas.edu/xmlui/handle/11531/31938> (accessed on 9 January 2023).
14. Warwick, P. An integrated leadership model for leading education for sustainability in higher education and the vital role of students as change agents. *Manag. Educ.* **2016**, *30*, 105–111. <https://doi.org/10.1177/0892020616653463>
15. Thomas, I. Sustainability in tertiary curricula: What is stopping it happening? *Int. J. Sustain. High. Educ.* **2004**, *5*, 33–47. <https://doi.org/10.1108/14676370410517387>
16. Jeans, H.; Thomas, S.; Castillo, G. *The Future is a Choice: The Oxfam Framework and Guidance for Resilient Development*; Oxfam GB: Oxford, UK, 2016. Available online: <https://oxfamilibrary.openrepository.com/bitstream/handle/10546/604990/ml-resilience-framework-guide-120416-en.pdf?sequence=1> (accessed on 11 November 2022).
17. Morfaw, J. Fundamentals of project sustainability. In Proceedings of the PMI® Global Congress 2014, Phoenix, AZ, USA, 25–28 October 2014.
18. Thiele, L.P. *Sustainability*, 2nd ed.; Polity Press: Cambridge, UK, 2016.
19. Mejías, A.; Martínez, D. Desarrollo de un instrumento para medir la satisfacción estudiantil en educación superior. *Docencia Univ.* **2009**, *10*(2), 29–47.
20. Gil, M.C. Educación a distancia: De la teoría a la práctica. *Perf. Educ.* **2000**, *22*, 89–92.
21. Vann Slyke, C.; Kittner, M.; Belanger, F. Identifying candidates for distance education: A telecommuting perspective. In Proceedings of the America’s Conference on Information System, Baltimore, MD, USA, 14–16 August 1998; pp. 666–668.
22. McArdle, G.E. *Training Design and Delivery*; American Society for Training and Development: Alexandria, VA, USA, 1999.
23. Kirkpatrick, D.L. *Evaluating Training Programs: The Four Levels*; Berrett Koehler Publishers: San Francisco, CA, USA, 1994.
24. Pereira, A.; Gelvez, L.N. Propuesta de un Modelo Latinoamericano para Apoyar la Gestión de Calidad de la Educación Virtual. Un Enfoque Dinámico Sistémico. Available online: <https://repositorial.cuaed.unam.mx:8443/xmlui/bitstream/handle/20.500.12579/5314/VEAR18.0426.pdf?sequence=1&isAllowed=y> (accessed on 11 November 2022).
25. Asociación Española de Normalización y Certificación. *Gestión de la Calidad. Calidad de la Formación Virtual*; (UNE 66181:2012); Asociación Española de Normalización y Certificación: Madrid, Spain, 2012.
26. Rodríguez, J.; Reguant, M. Calcular la fiabilidad de un cuestionario o escala mediante el SPSS: El coeficiente alfa de Cronbach. *REIRE Rev. D’innovació Recer. Educ.* **2020**, *13*, 1–13. <https://doi.org/10.1344/reire2020.13.230048>
27. Piza-Flores, V.; Aparicio, J.L.; Rodríguez, C.; Beltrán, J. Transversalidad del eje “Medio ambiente” en educación superior: Un diagnóstico de la licenciatura en contaduría de la UAGro. *RIDE. Rev. Iberoam. Investig. Desarro. Educ.* **2018**, *8*, 598–621.
28. Project Management Institute. *A Guide to the Project Management Body of Knowledge (PMBOK® Guide)*, 6th ed.; PMI: Newton Square, PA, USA, 2017.
29. International Organization of Standardization. *Orientación Sobre Gestión de Proyectos ISO 21500*; International Organization of Standardization: Geneva, Switzerland, 2012.
30. Bravo, B.; Dzul, L.; Gracia, S.; Fernández, F. Coordinación entre los niveles de gestión de proyectos: Portafolio, programa y proyecto. *Dyna* **2009**, *84*, 421–428.
31. Project Management Institute. *The Standard for Program Management*, 4th ed.; PMI: Newton Square, PA, USA, 2017.
32. Project Management Institute. *The Standard for Portfolio Management*, 4th ed.; PMI: Newton Square, PA, USA, 2017.
33. García, A.; Gracia, S.; Estay, C.; Cisteró, J.; Fernández, J.; Álvarez, A. Metodología de enseñanza-aprendizaje en diseño de proyectos de ingeniería. *Afinidad* **2007**, *64*, 456–463.
34. Soler, P.; Enrique, A.M. Reflexión sobre el rigor científico en la investigación cualitativa. *Estud. Sobre Mensaje Periodístico* **2012**, *18*, 879–888. https://doi.org/10.5209/rev_ESMP.2012.v18.40966
35. Hernández, R.; Fernández, C.; Baptista, P. *Metodología de la Investigación*, 3rd ed.; McGraw-Hill: Mexico City, Mexico, 2003. Available online: http://catarina.udlap.mx/u_dl_a/tales/documentos/lad/pinera_e_rd/capitulo3.pdf (accessed on 11 November 2022).
36. Pérez, F.J.; Martínez, P.; Martínez, M. Satisfacción del estudiante universitario con la tutoría. Diseño y validación de un instrumento de medida. *Estud. Sobre Educ.* **2015**, *29*, 81–101. <https://doi.org/10.15581/004.29.81-101>
37. Alianza Empresarial para el Desarrollo de Costa Rica. Política de Sostenibilidad en la Cadena de Valor AED. 2017. Available online: <https://www.aedcr.com/recursos/publicaciones/politica-de-sostenibilidad-en-la-cadena-de-valor-aed> (accessed on 11 November 2022).
38. Responsabilitat Social a Catalunya, Recursos Sobre els Objectius de Desenvolupament Sostenible (ODS). 2017. Available online: https://treball.gencat.cat/web/.content/13_-_consell_relacions_laborals/Coneixeu_nos/Activitat/Jornada_Eines_RS_setembre2018/GUIA_CATALA.pdf (accessed on 11 November 2022).
39. Cerrejón Minería Responsable. Informe de Sostenibilidad. 2017. Available online: <https://www.cerrejon.com/wp-content/uploads/informes/informe%20de%20sostenibilidad%202020.pdf> (accessed on 11 November 2022).
40. Global Reporting Initiative. *Sustainability Reporting Guidelines G4*; Global Reporting Initiative: Amsterdam, The Netherlands, 2013. Available online: <https://www.globalreporting.org/resourcelibrary/GRIG4-Part1-Reporting-Principles-and-Standard-Disclosures.pdf> (accessed on 11 November 2022).
41. United Nations. Pacto Mundial de Naciones Unidas. Una Llamada a la Acción Para Empresas Sostenibles. 2018. Available online: https://www.pactomundial.org/wp-content/uploads/2018/02/Flyer-New-Strategy-GC-2018_20180126.pdf (accessed on 11 November 2022).

42. International Organization of Standardization. *Environmental Management Systems ISO 14001*; International Organization of Standardization: Geneva, Switzerland, 2015.
43. International Organization of Standardization. *Occupational Health and Safety Management Systems-Requirements with Guidance for Use ISO 45001*; International Organization of Standardization: Geneva, Switzerland, 2018.
44. SAI. *Social Accountability International SA8000*; SAI: New York, NY, USA, 2008.
45. International Organization of Standardization. *Quality Management Systems ISO 9001*; International Organization of Standardization: Geneva, Switzerland, 2015.
46. Forética. SGE 21. Sistema de Gestión Ética y Socialmente Responsable. 2017. Available online: <https://foretica.org/sge21/> (accessed on 11 November 2022).
47. AccountAbility. Assuring Credibility in Reporting on Progress toward Sustainability Goals AA1000AS v3. 2018. Available online: <https://www.accountability.org/standards/> (accessed on 11 November 2022).
48. García, E. Elaboración de un Modelo y Aproximación a Una Norma de Gestión Empresarial para la Implantación de la RSC en la Organización. Ph.D. Thesis, Universidad Politécnica de Cataluña, Barcelona, Spain, 2010.
49. Raufflet, E.; Barin-Cruz, L.; Brès, L. An assessment of corporate social responsibility practices in the mining and oil and gas industries. *J. Clean. Prod.* **2014**, *84*, 256–270. <https://doi.org/10.1016/j.jclepro.2014.01.077>.
50. Vásquez, O. La idónea implementación estratégica es condición necesaria para aspirar al éxito de la empresa. *Estud. Gerenc.* **2002**, *18*(85), 41–66.
51. International Fund for Agricultural Development. Informe de Género e Inclusión Social: Región Andina. Available online: <https://www.ifad.org/en/> (accessed on 11 November 2022).
52. International Organization of Standardization. *Environmental Management. Life Cycle Assessment ISO 14040*; International Organization of Standardization: Geneva, Switzerland, 2006.
53. British Standards Institute (BSI). *PAS 2050: Specification for the Assessment of the Life Cycle Greenhouse Emissions of Goods and Services*; British Standards Institute (BSI): London, UK, 2011. Available online: <https://biolatina.com/wp-content/uploads/2018/08/PAS2050.pdf>. (accessed on 16 November 2022).
54. Valor, C.; Merino, A. *The NGO-Company Relationship in the Framework of Corporate Social Responsibility*; Center for Development Cooperation Studies: Madrid, Spain, 2005. Available online: http://www.solucionesong.org/ficheros/4c93617587fd0/estudio_ccecod.pdf (accessed on 16 November 2022).
55. Villaseñor, Y. Certificación integrada de sistemas de gestión de calidad y medio ambiente. *Boletín mensual de AENOR*, **2003**, *177*, 22–25.
56. Alva, A. Operacionalización de las Variables, s.f. Available online: http://cmapspu-public2.ihmc.us/rid=1177276915826_1221648340_5171/operacionalizacion.pdf (accessed on 11 November 2022).
57. Mejía, E. Operacionalización de Variables Educativas. Compilación 2008. Unidad de Post Grado de la Facultad de Educación de la Universidad Nacional Mayor de San Marcos. Available online: <https://investigacion-bge.jimdo.com/app/download/10120213660/Operacionalizaci%C3%B3n+de+Variables+Educativas.pdf?t=1408468203> (accessed on 16 November 2022).
58. Fernández, G. Propuesta de un Modelo para la Evaluación de la Sostenibilidad en la Dirección Integrada de Proyectos de Ingeniería Civil. Ph.D. Thesis, Universidad Politécnica de Madrid, Madrid, Spain, 2010.
59. Silvius, G.; Schipper, R.; Planko, J.; van den Brink, J.; Köhler, A. *Sustainability in Project Management*; Routledge Ltd: London, UK, 2017. Available online: <https://www.taylorfrancis.com/books/e/9781351896573> (accessed on 16 November 2022).
60. Zelada, R. Gestión de Proyectos Según la Guía del PMBOK®. Available online: <https://wbsburgos.files.wordpress.com/2011/07/presenacion-pmi.pdf> (accessed on 16 January 2023).
61. Drob, C.; Zichil, V. Overview regarding the main guidelines, standards and methodologies used in Project Management. *J. Eng. Stud. Res.* **2013**, *19*, 26–31.
62. Vanega, J.A. ¿Cómo incorporar los criterios y principios de la sostenibilidad en el diseño, construcción y gestión de infraestructuras? *Ekón. Rev. Vasca De Econ.* **2006**, *63*, 88–111.
63. Brotherton, S.A.; Fried, R.T.; Norman, E.S. Applying the work breakdown structure to the project management lifecycle. In *Proceeding of the PMI® Global Congress 2008—North America, Denver, CO, USA, 2008*.
64. UNE, Normalización Española. *Gestión de la Calidad*; Calidad de la Formación Virtual; UNE: Armidale, Australia, 2012; Volume 66181.

Disclaimer/Publisher's Note: The statements, opinions and data contained in all publications are solely those of the individual author(s) and contributor(s) and not of MDPI and/or the editor(s). MDPI and/or the editor(s) disclaim responsibility for any injury to people or property resulting from any ideas, methods, instructions or products referred to in the content.